



15-Inch AUTOMATIC SCRUBBER

www.usviper.com

# OWNERS MANUAL

IMPORTANT: READ OWNERS MANUAL CAREFULLY  
Please fill out & return your warranty card !

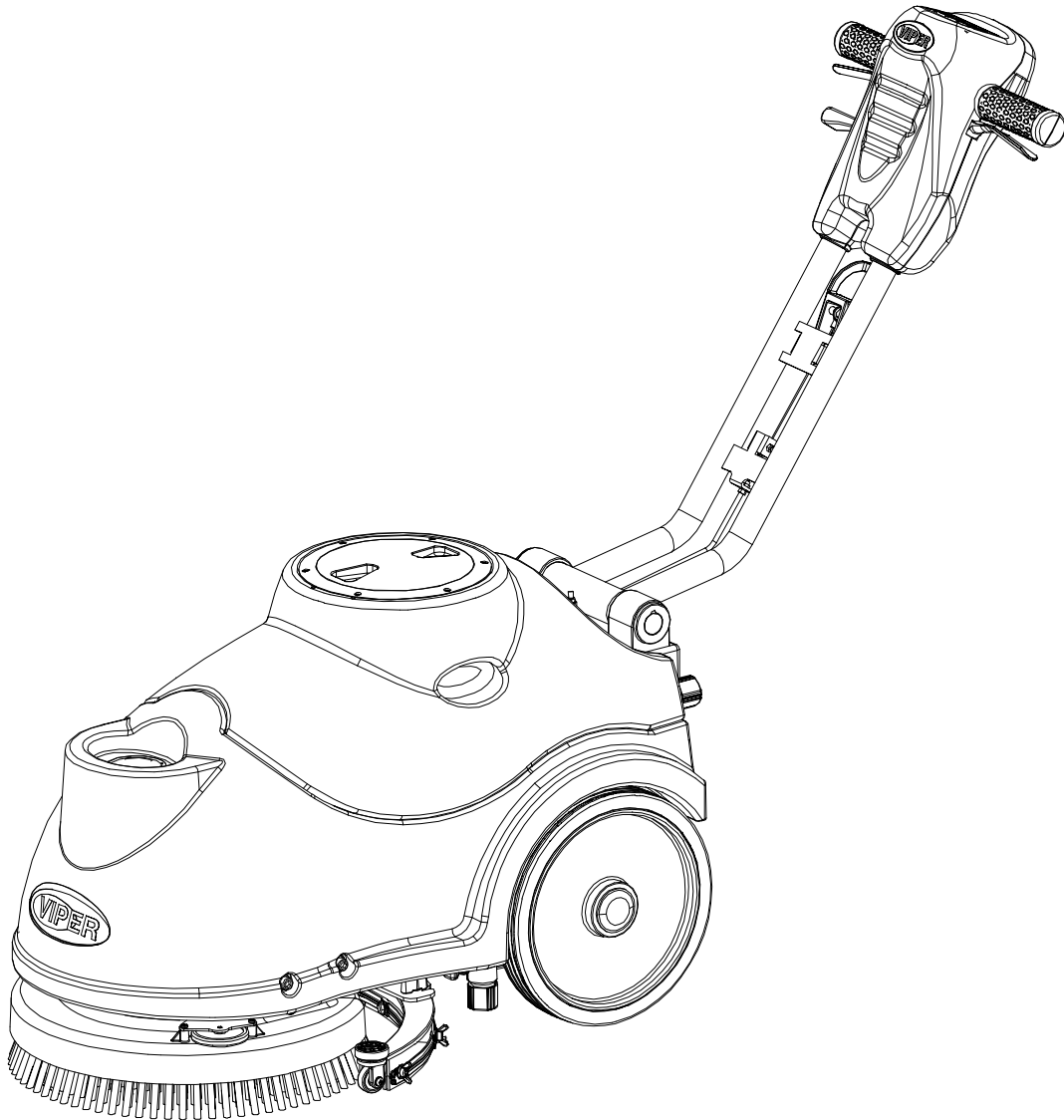

MODEL #	FANG15B
SERIAL #	_____

Nilfisk Inc.  
9435 Winnetka Avenue North  
Minneapolis, MN 55445  
www.usviper.com

VIPER...exceptional  
value  
VF89027-US REV.13  
2019-08

## **SAFETY PRECAUTIONS**

This machine is intended for commercial use. It is constructed for use in an indoor environment and is not intended for any other use. Use only with recommended accessories.

All operators shall read, understand and exercise the following safety precautions:

### **1) DO NOT OPERATE MACHINE:**

Unless trained and authorized.  
Unless you have read and understand the operators manual.  
In flammable or explosive areas.  
If not in proper operating condition.  
In outdoor areas.

### **2) BEFORE OPERATING MACHINE:**

Make sure all safety devices are in place and operate properly.

### **3) WHEN USING MACHINE:**

Go slow on inclines and slippery surfaces.  
Follow all safety guidelines.  
Be very careful when using the machine in reverse.  
Report and fix any damage to machine prior to operating it.

### **4) BEFORE LEAVING OR SERVICING MACHINE:**

Stop machine on level ground.  
Turn machine off.

### **5) WHEN SERVICING MACHINE:**

Read operators manual thoroughly prior to operating or servicing this machine.  
Use manufacturer supplied or approved replacement parts.  
Secure machine with wheel blocks prior to jacking the machine up.  
Use approved jack or hoist to safely elevate the machine.  
Disconnect batteries prior to working on machine.  
Wear gloves when handling batteries or battery cables.  
Avoid any contact with battery acid.  
Avoid moving parts; do not wear loose fitting clothing while servicing machine.



#### **WARNING!**

*Batteries emit hydrogen gas. Explosion or fire can result from hydrogen gas. Keep Sparks and open flames away! Keep battery compartment open when charging.*



#### **WARNING!**

*Flammable materials can cause an explosion or fire. Do not use flammable materials in tanks.*



#### **WARNING!**

*Flammable materials or reactive metals can cause explosion or fire .Do not pick up.*

## **MACHINE SET UP & INSTALLATION**

### **UNCRATING MACHINE**

Be sure and check packing carton for any damage. Immediately report any damage to carrier. Check contents of package to ensure that the following items are included:

1. Machine
2. Batteries(x2)
3. Squeegee assembly
4. Owners Manual
5. Electric Battery Charger Manual (if equipped)
6. Connecting wire for battery and charger (if equipped)
7. Brush

### **BATTERY DISASSEMBLY AND INSTALLATION**

1. Switch off the main switch. (47)
2. Remove the recovery tank. (2)
3. Remove the bolt from batteries. (16) Remove or change batteries.
4. Install the batteries on the machine according to the diagram below.
5. Install the recovery tank.



#### **WARNING**

*Do not connect+ to +,or - to-,when disassembly or install the batteries. It is very dangerous.*

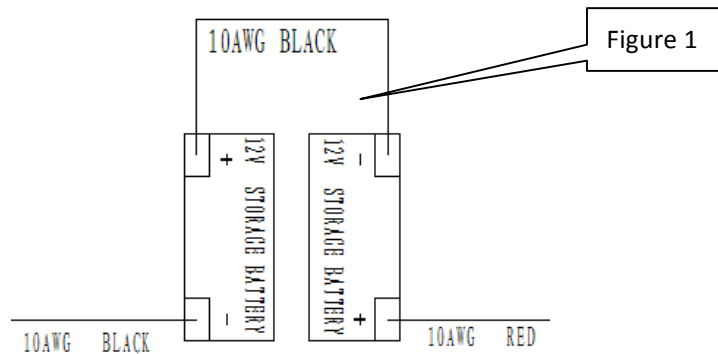

### **Battery charging**

Charge the batteries. (see Maintenance section)

## **MACHINE SET UP**

### **Pre-operation checks**

1. Sweep or dust mop the surface to be cleaned.
2. Check that squeegee is properly installed.
3. Lower the squeegee (33) with the lever. (26)
4. Ensure batteries are fully charged. (see Battery Charging section)
5. Check that brush is properly installed.

### **Brush/Pad driver installation and disassembly**



#### **NOTE**

*Only install manually. If automatically installed, it will wear brush hub.*

*Make sure that the tanks are empty before removing the brush.*

1. Turn off the machine.
2. Lay down the machine in the position shown in figure 2. Pull up lift lever (26) to raise the squeegee. (33)

3. Mount the brush or pad driver onto the drive wheel hub and then rotate counterclockwise until it locks, as indicated in figure3.
4. To remove the brush/pad, rotate the brush/pad clockwise until it is released from drive hub.



**WARNING**

*Do not turn on the machine in this position as below. In case of brush/pad come out or cause injury.*

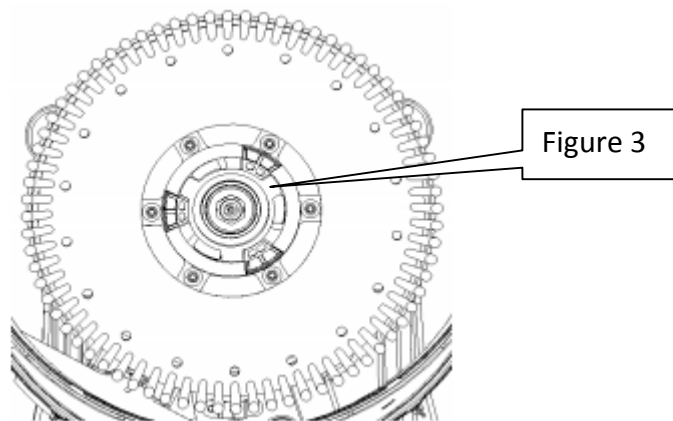
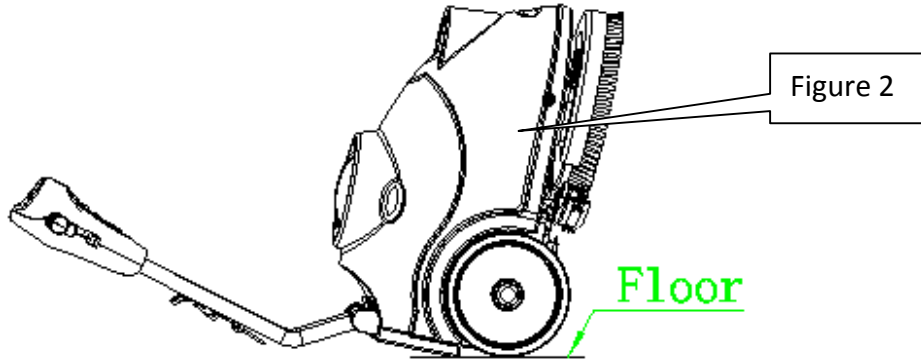

**Squeegee installation**

1. Turn off the machine. (47)
2. Pull down the squeegee lift lever (26) to put down the squeegee in the “working” position.
3. Lay down the machine in this position as shown in figure2.
4. Loosen the two knobs (55) on the squeegee and slide the squeegee into the slots on the squeegee brackets.
5. Tighten the knobs securely. (unscrew the knobs, if to remove)
6. To replace the front/rear squeegee, (56/57) unscrew the thumb knobs. (37)

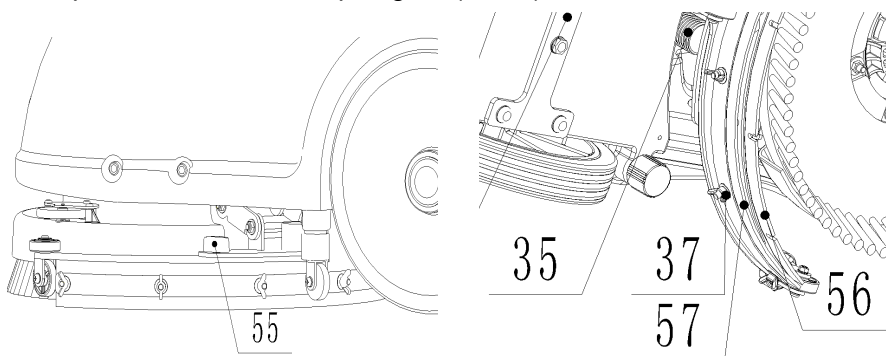

### Solution tank filling



#### NOTE

*The machine can be filled with a hose or bucket. Do not remove the Solution filter (21) while filling.*

1. Fill water into solution tank (3) from the inlet (20) through hose or bucket.
2. Do not overfill the solution tank. It is best to leave a an inch from the top edge.
3. The water temperature must not exceed 40°C.



#### CAUTION!

*Use only low-foam and non-flammable detergents, intended for automatic scrubber applications.*

### Solution tank draining



#### NOTE

*Solution tank should be drained and cleaned after each scrubber operation is completed.*

1. Unscrew the drain cap (22) on the bottom of solution tank. The solution/water will flow freely into a bucket or floor drain.
2. Rinse the solution tank with clean water after every use. This will help prevent chemical buildup and clogging of the solution lid.
3. Replace the drain cap. (22)

### Recovery tank draining



#### NOTE

*Recovery tank should be drained and cleaned after each scrubber operation is completed.*

1. Turn the latch (17) on the recovery tank. Remove the recovery tank from machine by grasping two grooves of tank and pulling up. Open the lid (1) and overturn the recovery tank to drain the dirty water into a container, or unscrew the drain cap (22) to let water drain into a bucket.
2. Clean and Rinse the recovery tank with clean water after every use.
3. Re-place the recovery tank on the machine and turn the latch (17) to lock the tank in place.

## MACHINE OPERATION

1. Set the handle to a comfortable height by pressing level. (25)
2. Lower the squeegee (33) onto floor by pulling down the lift handle. (26)
3. Turn on the main power switch. (47)
4. Turn on the brush motor switch (48) and the solution switch. (50)
5. Turn on the vacuum motor switch. (49)
6. If necessary, adjust the water flow by manually turning the ball valve. (31)
7. Pull one or both operating triggers. (24) The brush will spin & solution will begin to flow. Push the machine forward to start cleaning.



#### NOTE

*If the battery indicator light (51) is green, the machine can be used. If it is yellow or red, the batteries must be charged.*

**CAUTION!**

*Before lifting the brush, turn off the main power switch. (47)*

**CAUTION!**

*If the control panel (46) lights flash simultaneously, this indicates the machine is overloaded. Please turn off all the switches on the control panel (46) to reset the machine. If problem persists, contact authorized service provider.*

**CAUTION!**

*Operating machine with discharged batteries may cause harm to the batteries or to the machine.*

**AFTER EACH USE**

After scrubbing, please proceed with below actions before storing the machine:

1. Remove the brush / pad-holder.
2. Empty the tanks as shown in the previous paragraph.
3. Perform the daily maintenance procedures. (see Maintenance section)
4. Store the machine in a clean and dry place, with the brush / pad-holder and the squeegee up.
5. If storing in an area that may reach freezing temperatures, be sure to drain all fluids from the machine prior to storage. Any damage caused by freezing will void the warranty.

**MACHINE STORAGE**

If the machine is not going to be used for more than 30-days, please proceed with below actions:

1. Perform the procedures shown in 'After Each Use' section above.
2. Disconnect the battery connector.

**MAINTENANCE**

The lifespan of the machine and its maximum operating safety are ensured by correct and regular maintenance. The following chart provides the scheduled maintenance. The intervals shown may vary according to individual working conditions.

**WARNING**

*Maintenance procedures must be performed with the machine switched off and the batteries/battery charger cable disconnected. Moreover, carefully read the instruction in the Safety chapter.*

All maintenance procedures must be performed by qualified personnel, or by an authorized Service Center.

This Manual describes only the most common maintenance procedures.

For additional maintenance procedures, contact your local Service Center.

**SCHEDULED MAINTENANCE TABLE**

Procedure	After each use	Weekly	Every six months	Annually
Battery charging				
Squeegee cleaning				
Brush cleaning				
Clean tank, vacuum screen & check top cover gasket				
Squeegee blade check and replacement				
Inlet filter cleaning				
Screw and nut tightening check			(1)	
Lubricate rotary parts			(1)	
Check brush motor carbon brushes				(2)
Check vacuum motor carbon brushes				(2)

(1) After the first 8 working hours.

(2) This maintenance procedure must be performed by an authorized Service Center.

**BATTERY CHARGING**



**NOTE**

*Charge the batteries when the yellow or red indicator, (51) or at the end of every work cycle.*



**CAUTION!**

*Proper battery care will extend battery life*



**CAUTION!**

*If the machine is not equipped with on-board battery charger, choose an external battery charger suitable for the type of batteries installed.*



**WARNING!**

*Please use Viper approved charger to charge the batteries.*

1. Place charger and machine in a well ventilated area.
2. Turn machine off. (47)
3. Remove the recovery tank, (2) exposing battery compartment.
4. Plug the charging cable to the grounded wall outlet (100v~240v). Connect the charging cable to the machine socket.
5. The charging light (30) indicates the batteries are charging. A green light indicates battery charging is completed.
6. Upon the completion of charging, first unplug the charging cable from the wall outlet and then disconnect from machine.
7. Replace the recovery tank.



**NOTE**

*For further information about the operation of the battery charger, (29) see the charger section.*

### Battery Charging Curve Set Up



**WARNING!**

*Do not set charger unless you have professional training*

1. Turn off the machine and disassemble the cover (A as Figure 4) from the machine. Then remove the round black cap located on the front side of the charger (B as Figure 4). you will find the 2 sets of dipswitches (SW1 and SW2) in the charger.
2. Only the DP1 of dip switch SW2 has effect on charging curve selection accordingly to the table below. The other switches should be always OFF.

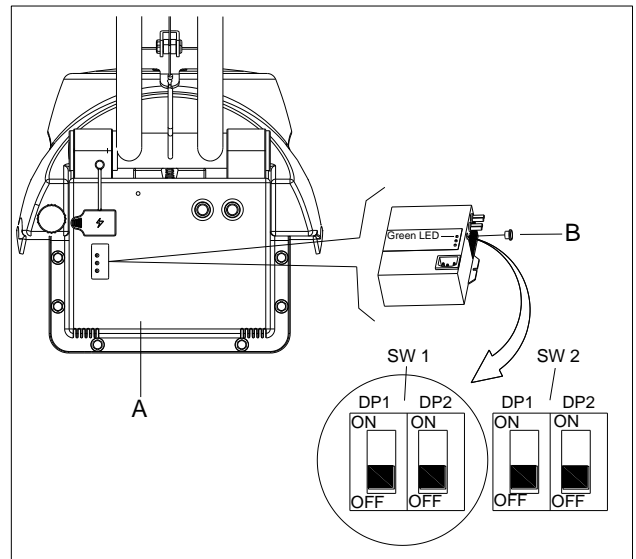

Figure 4

SW2 DP1	CHARGING PROFILE	CHARGER LED STATUS WHEN POWER ON
ON	IUIa-AGM for Discover AGM batteries	Red LED flash twice
OFF	IU0U-AGM/GEL of other manufacturers (default setting)	Green LED flash twice



## Battery Discharge Cut Off Voltage Set Up



### WARNING!

**Do not set PCBA unless you have professional training**

1. Turn off the machine and disassemble the cover (A as Figure 5) from the machine. You will find the main control PCBA (B as Figure 5). There are 2 switches (DP1 and DP2) in the PCBA.
2. Configure the DP1 and DP2 accordingly to the table below. It is used for defining the battery discharge cut off voltage.

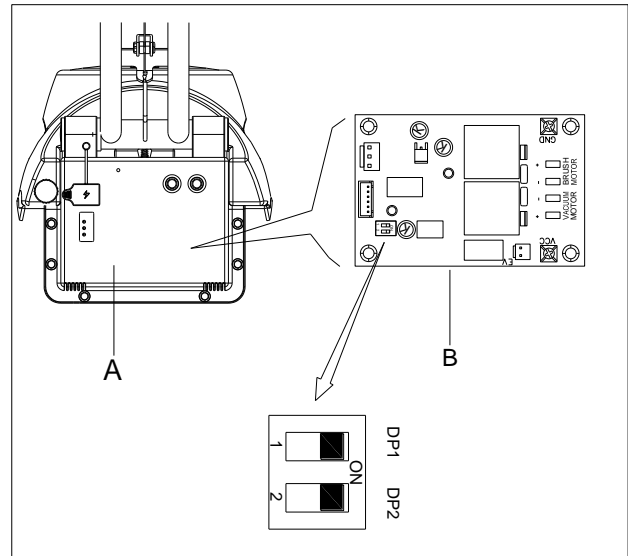

Figure 5

DP1	DP2	Battery type	Dashboard LED status when power on
ON	OFF	Discover-EV	Power green & red LED flash twice
ON	ON	GEL/AGM (default setting)	Power green LED flash twice

## SQUEEGEE CLEANING



### NOTE

**For optimal performance, the squeegee blades must be clean, dry and undamaged.**



### CAUTION !

**It is advisable to wear protective gloves when cleaning the squeegee because there may be sharp debris.**

## SQUEEGEE BLADE CHECK AND REPLACEMENT

1. Take off the squeegee as shown in the previously.
2. Check the edges of the front & rear blades for cracks. If necessary replace with new blades.
3. Unscrew six the thumb nuts (37) to remove the blades.
4. Check the front & rear blades for cuts and tears. If damage is found, you can flip the blades once & re-install. If already flipped, please replace with new blades.
5. Install the squeegee in the reverse order of removal.

## BRUSH /PAD DRIVER CLEANING



### CAUTION!

*It is advisable to wear protective gloves when cleaning the brush/pad because there may be sharp debris.*

1. Remove the brush/pad as shown in “Machine Use” section.
2. Clean and wash the brush/pad with water and detergent.
3. Check the brush bristles for integrity and wear. If necessary, replace the brush.
4. Check the pad for wear. If necessary, replace the pad driver.

## RECOVERY TANK MAINTENANCE



### CAUTION!

*It is advisable to wear protective gloves when cleaning the tank and vacuum/suction assembly because there may be sharp debris.*

1. Move the machine to the appointed draining area.
2. Turn off the main switch. (47)
3. Remove the recovery tank, (2) clean and rinse both solution/recovery tank, and drain out.
4. Remove vacuum gasket & filter. Clean and re-install.
5. Check the recovery tank lid gasket and the vacuum rubber connector (18) for wear. Replace if necessary.



### NOTE

*The gasket ring of recovery tank and the rubber connector between two tanks create vacuum in the tank. If necessary, replace them.*

**Control Panel**

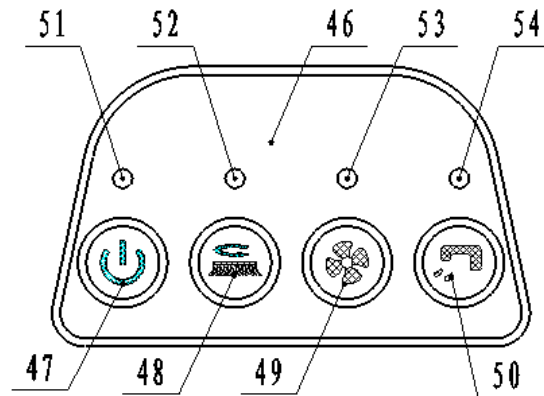

- 46. Control panel
- 47. Main switch
- 48. Brush motor switch
- 49. Vacuum motor switch
- 50. Solution switch
- 51. Battery indicator
- 52. Brush motor indicator
- 53. Vacuum motor indicator
- 54. Solution indicator

**TECHINICAL DATA**

MODEL	FANG15B
Machine length / width / height	770x500x550MM
Solution tank capacity	15L
Recovery tank capacity	15L
Wheel diameter	254MM
Brush motor	24V/250W
Vacuum motor	24V/300W
Solenoid valve	24V
Maximum gradient when working	2%
Sound level	70dBA
Standard Batteries	Dry: (2×12V) 24V 33Ah
Batteries size	196 x 130 x 175mm
Power cable length	N / A
Cleaning productivity	750m <sup>2</sup> /hour
Squeegee width	490mm
Brush diameter	380mm
Brush rpm	150rpm
Charger	Input 110–224Vac, 50–60HZ; Output 24Vdc, 5A
Machine net weight	60kg
Machine weight (with charger and package)	65kg
Carton spec	780x415x590MM

COMPLETE ASSEMBLY

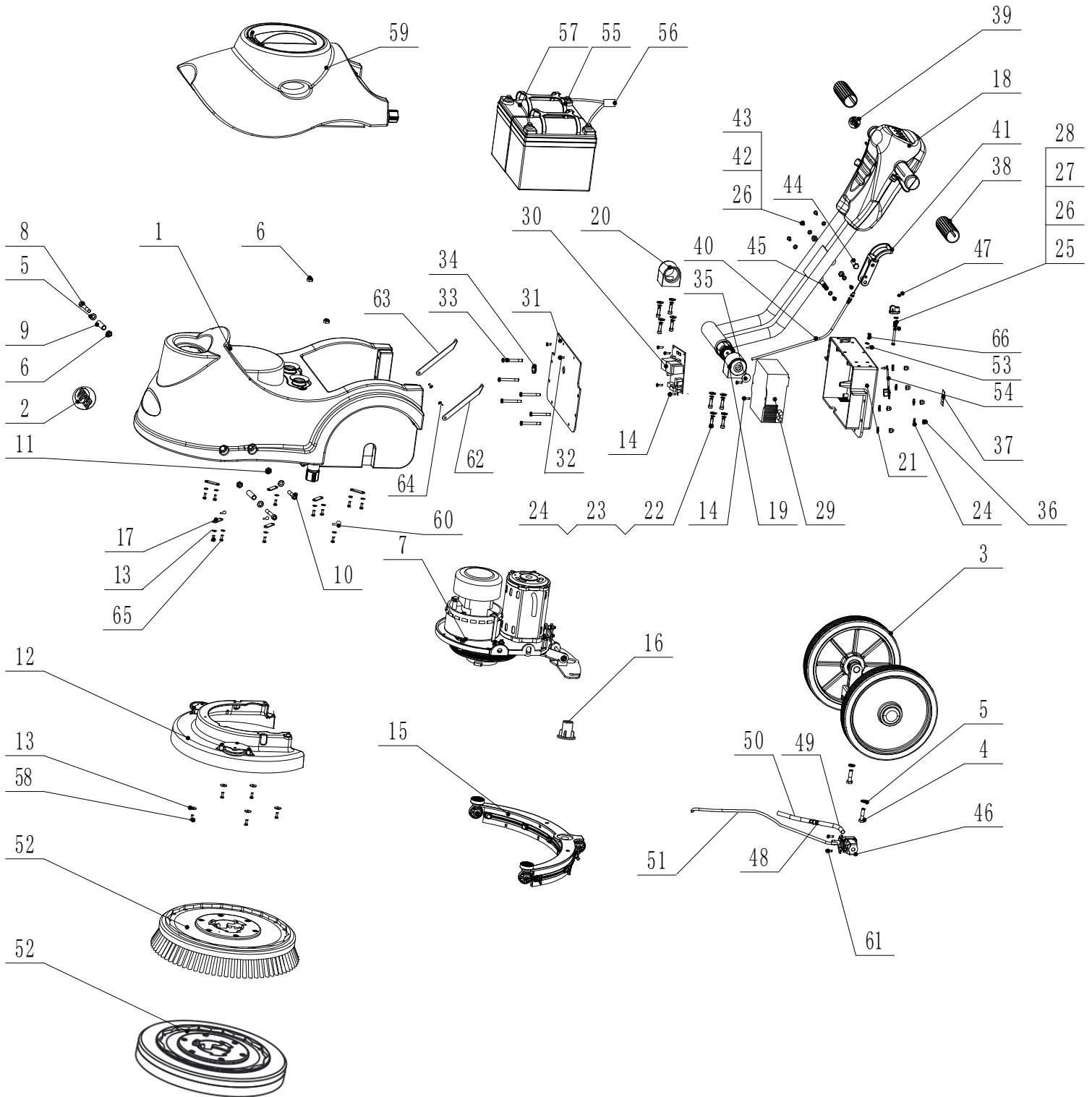

COMPLETE MACHINE - FANG15B			
Item	Part No.	Description	Qty
1	VF89100	KIT, SOLUTION TANK	1
2	VF89018	LABEL, SOLUTION TANK	1
3	VF89200	KIT, AXLE WHEEL	1
4	VF14251	BOLT, M8X30, HEX HEAD	2
5	VF13514A	WASHER, D8X1XD16.5	5
6	VF14516	NUT, NYLON INSERT, M8	4
7	VF89831	KIT, MOTOR MOUNTING PLATE	1
8	VF85698	HEX SOCKET SCREW, M8X55	2
9	VF89030	BUSHING	2
10	VF14258	HEX SOCKET SCREW, M8X40	1
11	VF14503	NUT, M8	1
12	VF89400	KIT, SKIRT ASSEMBLY	1
13	VV13664	WASHER, D4X1XD8	15
14	VF13491	PH SCREW, M4X12	16
15	VF89821	KIT, SQUEEGEE	1
16	VF89029A	HOSE, CONNECT SQUEEGEE	1
17	VF89015	PLATE	6
18	VF89600	KIT, HANDLE ASSEMBLY	1
19	VF89001	HANDLE BLOCK, LEFT	1
20	VF89002	HANDLE BLOCK, RIGHT	1
21	VF89003	CIRCUIT BOX	1
22	VV60220S1	HEX SOCKET SCREW, M6X15	8
23	VV20290	WASHER LOCK, $\phi$ 6	8
24	VF13614	WASHER, $\phi$ 6	14
25	GT13027	PH SCREW, M5X45	1
26	VA13482	WASHER, D5X1XD10	6
27	VF89004	LATCH, RECOVERY TANK	1
28	VF89005	SPRING, PRESS	1
29	VF89023US	KIT, CHARGER	1
30	VF89025-1	PLATE, MAIN CONTROL	1
31	VF89006	CIRCUIT COVER	1
32	VF14301	SCREW, M4X12	2
33	VF89034	HEX BOLT M6X50	4
	VF89034A	HEX BOLT M6X55	2
34	VF89052	COVER, WATERPROOF	1
35	VF89037	PLUG, RUBBER	1
36	VF89035	COVER NUT, M6	6
37	VF89016	LABEL, CHARGE DISPLAY	1
38	VF89012	HANDLE GRIP, RUBBER	2
39	VF89017	LABEL, REAR HOUSING	1
40	VF89007	CABLE, SQUEEGEE LIFT	1
	VF89007-1	CABLE, SQUEEGEE LIFT	1
41	VF89008	HANDLE, SQUEEGEE LIFT	1
42	VV20509	PH SCREW, M5X10	3
43	VF89010	ROTATE AXLE, SQUEEGEE LIFT CABLE	2
44	VF89011	AXLE, SQUEEGEE LIFT CABLE	1
45	VF89009A	ROTATE AXLE, SQUEEGEE LIFT CABLE	2
46	VF89056	SOLENOID VALVE, 24V	1
47	VF14514	NUT, NYLON INSERT, M5	1
48	VF89033	HOSE	1
49	VF89847	PIPE SI, D6XD10, 0.115M	1
50	VF89848	PIPE SI, D4XD8, 0.115M	1
51	VF89846	PIPE SI, D6XD10, 0.45M	1
52	VF89830	BRUSH ASSEMBLY	1
	VF89817	PAD DRIVER	1

COMPLETE MACHINE - FANG15B			
Item	Part No.	Description	Qty
53	VF85102	SMALL CLAMP	1
54	VF89055	RUBBER PLUG, CHARGER INSERT	1
55	VF89020	BATTERY, 12V 35Ah	2
56	VF89036	POWER WIRE	1
57	VF89021	KIT, BATTERY CONNECT LINE	1
58	VA13473	PH SCREW, M4X16	5
59	VF89827	KIT, RECOVERY TANK	1
60	VF85141	BIG CLAMP	1
61	VA13472	PH SCREW, M4X8	2
62	VS00001	SUPPORT,LEFT	1
63	VS00002	SUPPORT,RIGHT	1
64	GT13054	SCREW, M5X12	2
65	VV13650A	SCREW, M4X10	11
66	VF14214	SCREW, M5X8	1

SOLUTION TANK ASSEMBLY

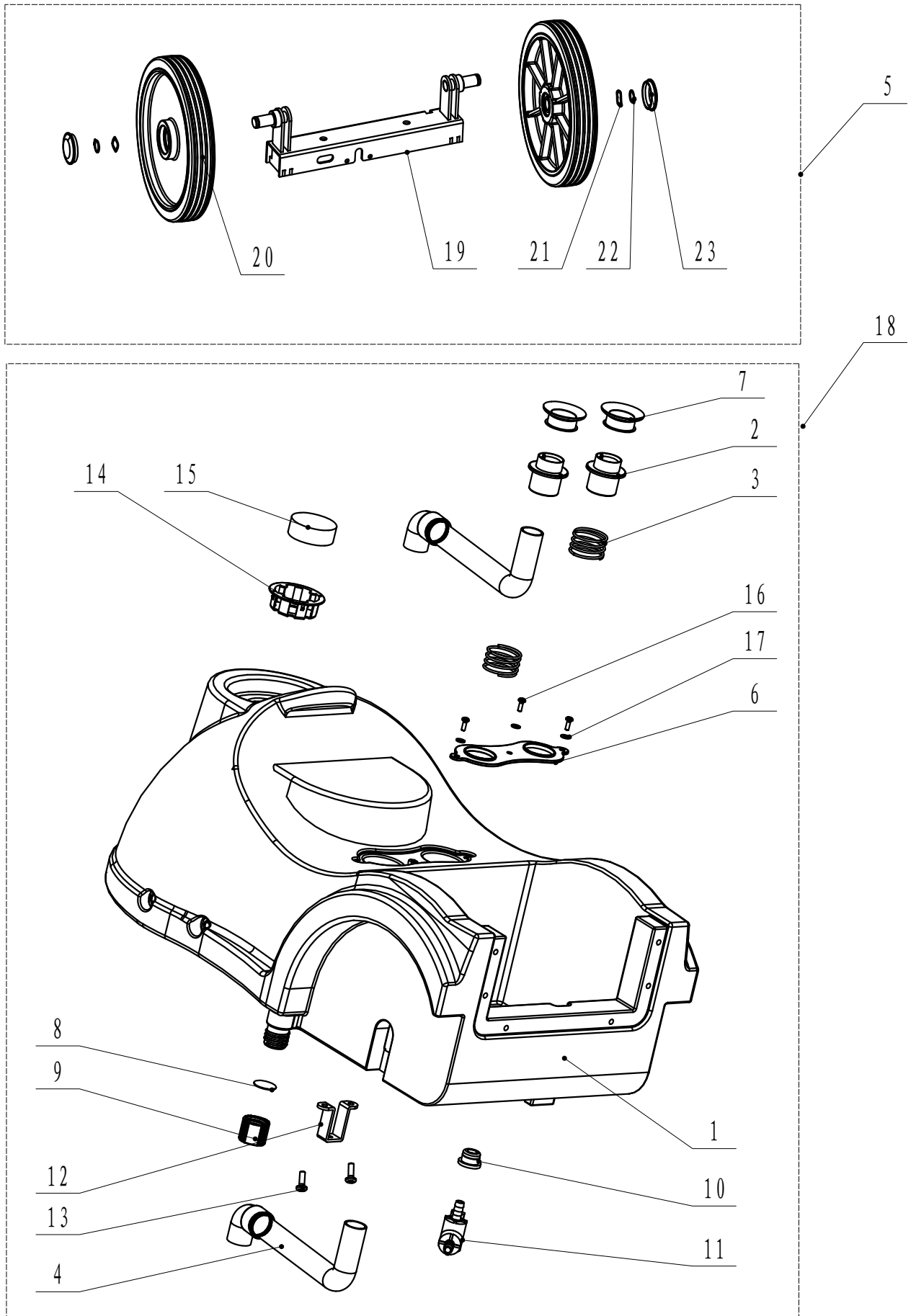

SOLUTION TANK ASSY - FANG 15B			
Item	Part No.	Description	Qty
1	VF89101	SOLUTION TANK	1
2	VF89102	HOSE, CONNECT VACUUM	2
3	VF89103	SPRING, PRESS	2
4	VF89104	VACUUM HOSE	2
5	VF89200	KIT, WHEEL AXLE	1
6	VF89106	PLASTIC PLATE, HOSE LIMIT	1
7	VF89107	RUBBER SEAL	2
8	VF89115	GASKET	1
9	VF89110	CAP, DRAIN	1
10	VF85302	RUBBER BUSHING	1
11	VF89091	SOLUTION TAP	1
12	VF89112	CABLE BRACKET	1
13	VF14200	PH SCREW, M6X15	2
14	VF89113	SEAT, INLET, FRESH WATER TANK	1
15	VF89114	FILTER, INLET, FRESH WATER TANK	1
16	VF13491	PH SCREW, M4X12	3
17	VV13664	WASHER $\phi$ 4	3
18	VF89100	KIT, SOLUTION TANK	1
19	VF89201	WHEEL AXLE	1
20	VF89202	DRIVE WHEEL, 10"	2
21	VF14563	WASHER,WAVE	2
22	VF14552	SNAP SPRING	2
23	VF89202-3	CAP, WHEEL	2



# PART LIST

## BRUSH DECK ASSEMBLY

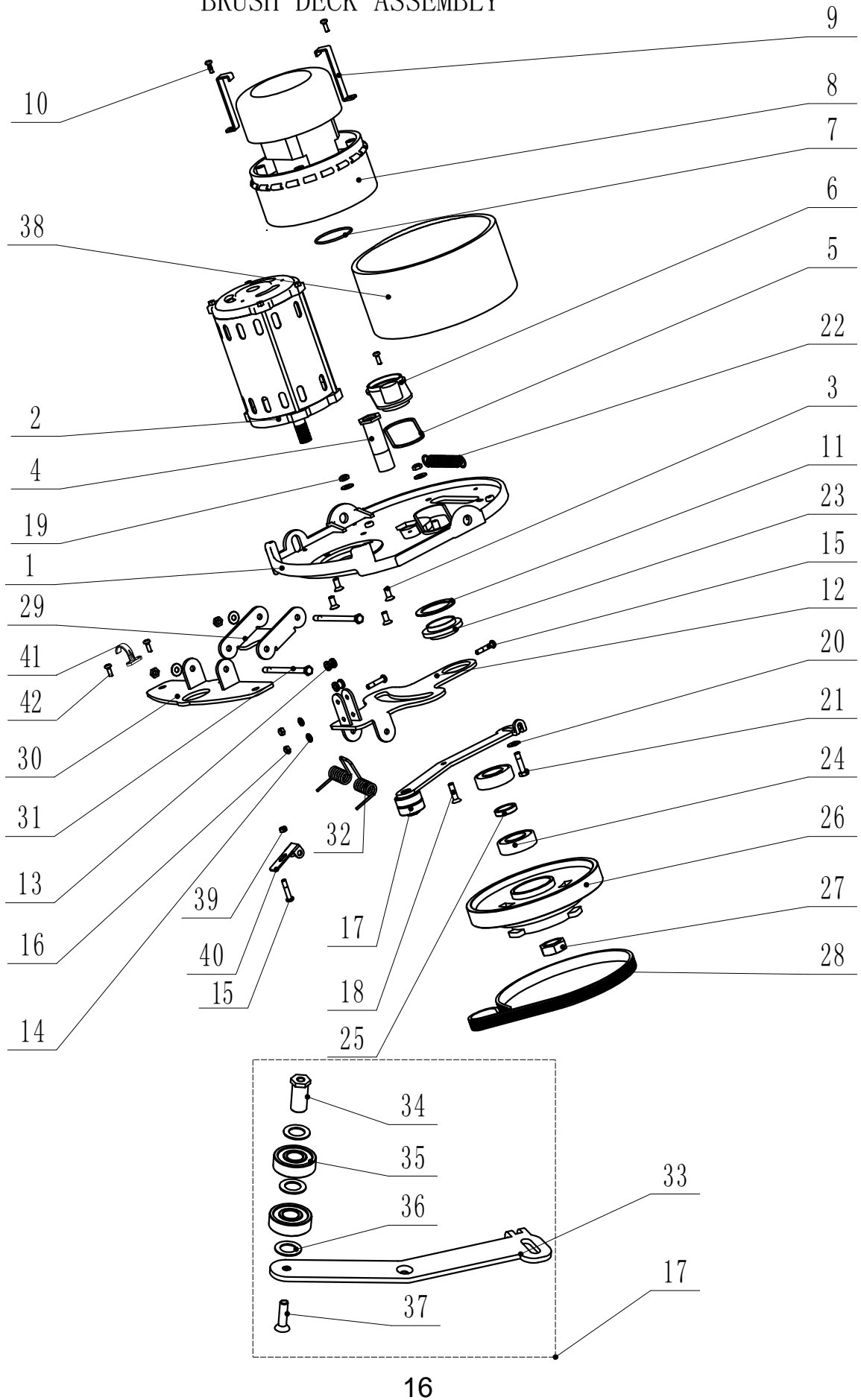

BRUSH DECK ASSY - FANG 15B			
Item	Part No.	Description	Qty
1	VF89301	PLATE, MOTOR MOUNT	1
2	VF89302	BRUSH MOTOR ASSEMBLY (Up to serial number FANG15B 004160)	1
	VF89342	BRUSH MOTOR ASSEMBLY (From serial number FANG15B 004161)	1
3	VF89303	SCREW, M6X14	4
4	VF89304	BOLT, DIRVE BELT	1
5	VF89305	O-RING, BIG	1
6	VF89306	SEALING COVER, VACUUM	1
7	VF89307	O-RING, SMALL	1
8	VF89309	KIT, VACUUM MOTOR (Up to serial number FANG15B 004160)	1
	VF89341	KIT, VACUUM MOTOR (From serial number FANG15B 004161)	1
9	VF89310	BRACKET, VAC MOTOR	2
10	VF13491	PH SCREW, M4X12	3
11	VF89311	WASHER, THIN	1
12	VF89312	PLATE, SQUEEGEE ROTATE	1
13	VF89313	GUIDE WHEEL, SQUEEGEE	2
14	VA13482	WASHER $\phi$ 5	2
15	VA13475	PH SCREW, M5X25	3
16	VF14514	NUT, NYLON INSERT, M5	2
17	VF89314	KIT, BELT ADJUSTMENT	1
18	VF14223	SCREW, M6X25	1
19	VF14506	NUT, NYLON INSERT, M6	4
20	VF13614	WASHER, $\phi$ 6	3
21	VV20058	BOLT, M6X25, HEX	1
22	VF89318	SPRING	1
23	VF89319	BUSHING, SQUEEGEE ROTATE	1
24	ZD45425	BEARING, 6204	2
25	VF89320	BUSHING	1
26	VF89321	DRIVE HUB	1
27	VF89322	NUT, M20	1
28	VF89323	DRIVE BELT, PJ270	1
29	VF89324	PLATE, SQUEEGEE LIFT	1
30	VF89325	PLATE, SQUEEGEE BRACKET	1
31	VF89326	ROTATE BOLT, SQUEEGEE LIFT	2
32	VF89823	TORSION SPRING	1
33	VF89315	PLATE, BELT ADJUSTMENT	1
34	VF89316	BOLT, BEARING	1
35	VF51126A	BEARING, 6201	2
36	VF89317	WASHER, D12.2XD20X1	3
37	GT13084	SCREW, M6X20	1
38	VF89308	SILENCER SPONGE	1
39	VV13633	NUT, M5	1
40	VF89337A	PRESSURE ADJUSTMENT PLATE	1
41	VF89092	CLAMP DRAIN HOSE	1
42	VV13667	SCREW, M4X8	2

PART LIST

BRUSH SKIRT & BRUSH

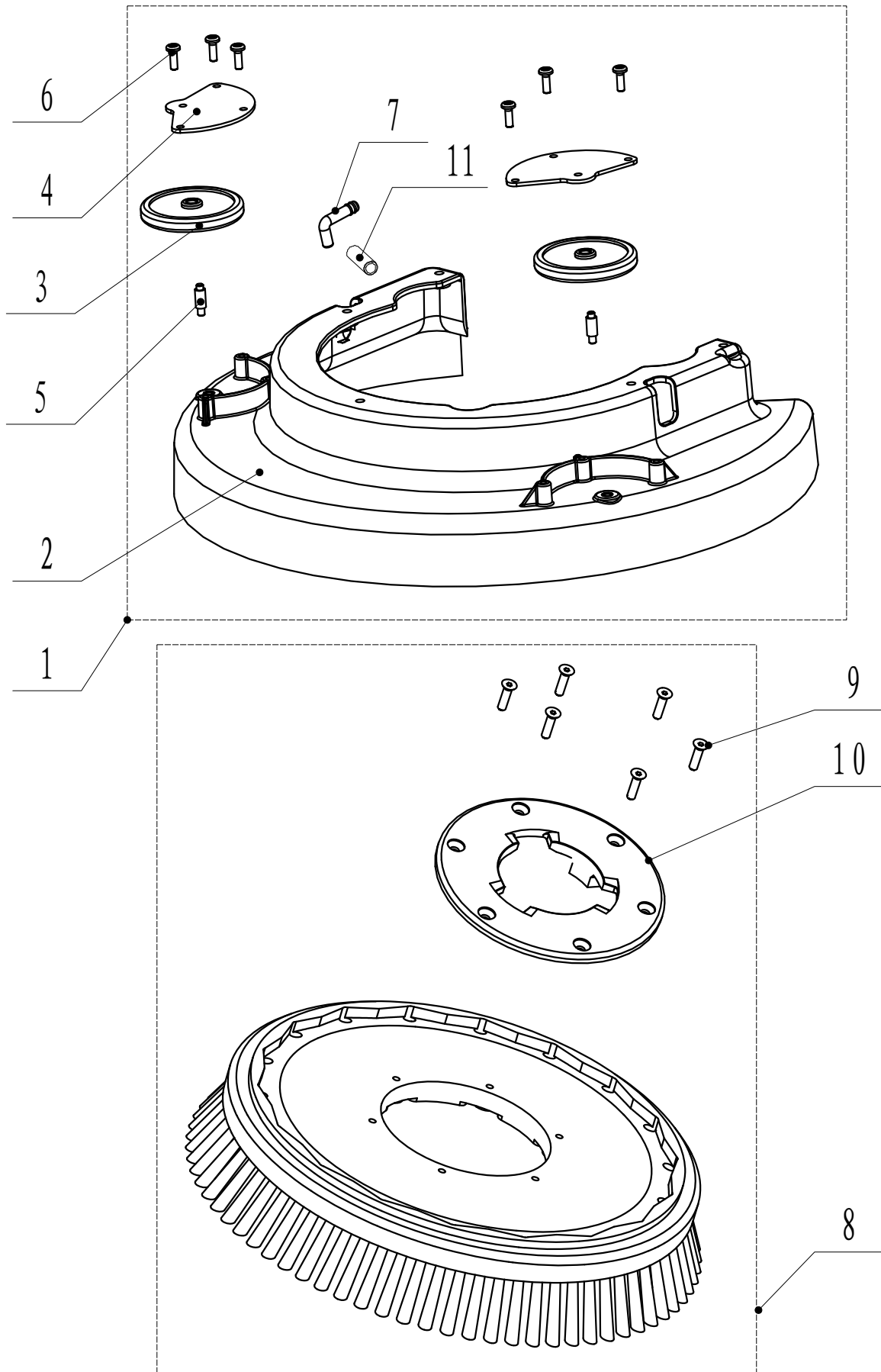

BRUSH SKIRT & BRUSH - FANG 15B			
Item	Part No.	Description	Qty
1	VF89400	BRUSH SKIRT ASSEMBLY	1
2	VF89401	BRUSH SKIRT	1
3	VF89402	WHEEL, BUMPER	2
4	VF89403	COVER, WHEEL	2
5	VF89404	SHAFT	2
6	VF14401	SCREW, ST4X10	6
7	VF89051	ELBOW	1
	VF89838	ELBOW	1
8	VF89830	BRUSH ASSEMBLY	1
	VF89817	PAD DRIVER ASSEMBLY	1
9	MF-VF002-4A	SCREW, ST6.5X25	6
10	VF89803	BRUSH HUB	1
11	VF89824	HOSE	1

HANDLE CONTROL ASSEMBLY

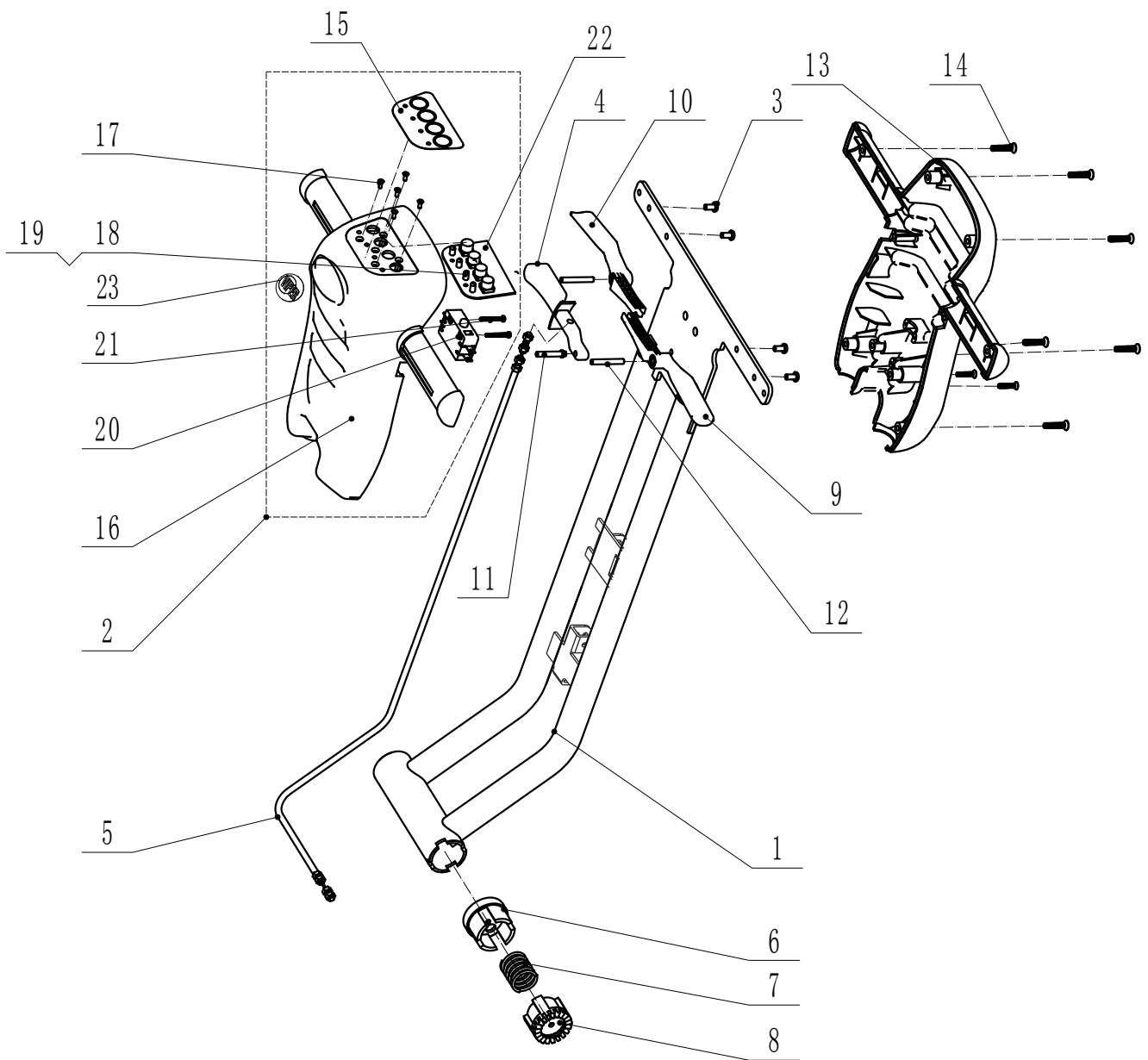

HANDLE ASSY - FANG 15B			
Item	Part No.	Description	Qty
1	VF89601	HANDLE TUBE ASSY	1
	VF89601A	HANDLE TUBE ASSY	1
2	VF89607	KIT, FRONT CONTROL HOUSING	1
3	80405A	PH SCREW, M5X12	4
4	VF89610	TRIGGER, HANDLE ADJUSTMENT	1
5	VF89611	CABLE, HANDLE ADJUSTMENT	1
6	VF89612	BUSHING, GUIDE GEAR	1
7	VF89613	SPRING, HANDLE GEAR	1
8	VF89614	GEAR, HANDLE ADJUSTMENT	1
9	VF89615	TRIGGER, LEFT	1
10	VF89616	TRIGGER, RIGHT	1
11	VF89617	PIN, HANDLE ADJUSTMENT	1
12	VF89621	PIN, TRIGGER	2
13	VF89618	CONTROL HOUSING, REAR	1
14	VF80407A	PH SCREW ,M5X25	8
15	VF89619	LABEL, SWITCH	1
16	VF89608	CONTROL HOUSING, FRONT	1
17	33005101	PH SCREW, M3X8	5
18	VF89622	BOLT, INSULATION, M3X15	5
19	VV13617	NUT, M3	5
20	VF40263A	SWITCH	1
21	VF14244	PH SCREW, M3X20	2
22	VF89025-2	CIRCUIT BOARD	1
23	VF89017	LABEL, CONTROL HOUSING	1

RECOVERY TANK ASSEMBLY

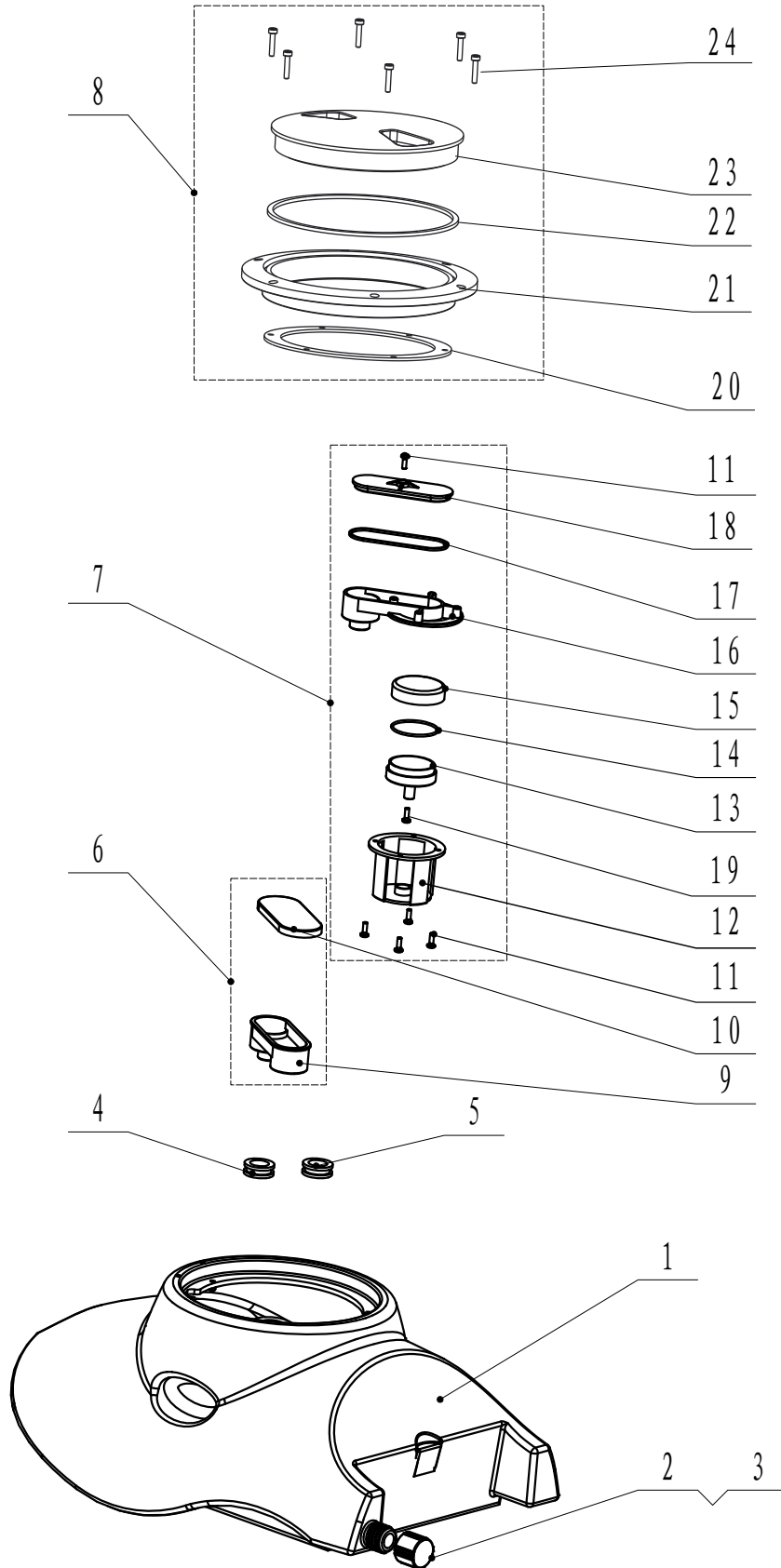

RECOVERY TANK - FANG 15B			
Item	Part No.	Description	Qty
1	VF89701	RECOVERY TANK	1
2	VF89115	GASKET	1
3	VF89110	CAP, DRAIN	1
4	VF89810	RUBBER BUSHING, TANK	1
5	VF89811	RUBBER BUSHING, TANK, GREY	1
6	VF89828	KIT, SQUEEGEE SUCTION	1
7	VF89829	KIT, SQUEEGEE VACCUM	1
8	VF89716	KIT, RECOVERY TANK COVER	1
	VF89716A	KIT, RECOVERY TANK COVER	1
9	VF89813	BASE, OUTLET	1
10	VF89712	COVER, RUBBER	1
11	VF14401	SCREW, ST4X9.5	5
12	VF89709	GUIDE BASE, PLUG VACUUM	1
13	VF89711	PLUG, BASE	1
14	VF89307	O-RING, PLUG	1
15	VF89710	PLUG, COVER	1
16	VF89814	BASE, VACUUM	1
17	VF89705	O-RING	1
18	VF89706	COVER, VACUUM	1
19	VA13477	SCREW, ST4X15	1
20	VF89077	SEAL, LID	1
21	VF89079	SEAT, FOR LID	1
22	VF89078	SEAL, LID	1
23	VV96001S	LID, RECOVERY TANK	1
24	VF89080	SCREW, M4X12	6



SQUEEGEE ASSEMBLY

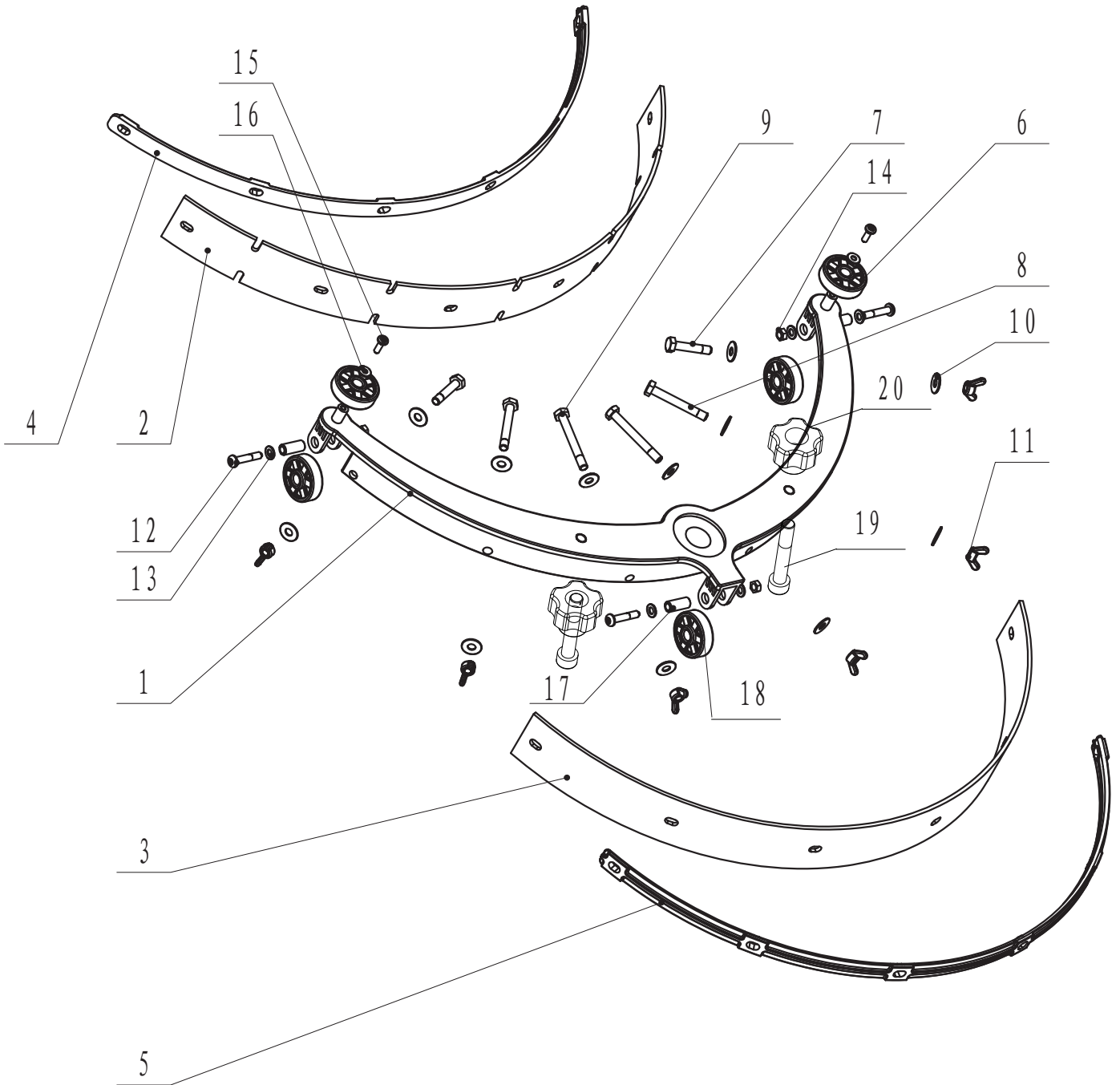

SQUEEGEE ASSY - FANG 15B			
Item	Part No.	Description	Qty
1	VF89815	SQUEEGEE BRACKET	1
2	VF89807	SQUEEGEE BLADE, FRONT	1
	VF89807-PU	SQUEEGEE BLADE, FRONT (PU - OPTIONAL)	1
3	VF89808	SQUEEGEE BLADE, REAR	1
	VF89808-PU	SQUEEGEE BLADE, REAR (PU - OPTIONAL)	1
4	VF89504	STRAP, SQUEEGEE FRONT	1
5	VF89505	STRAP, SQUEEGEE REAR	1
6	VF89506	WHEEL, SQUEEGEE	2
7	VA13479	BOLT, M6X30, HEX STAINLESS	2
8	VF89507	BOLT, M6X45, HEX STAINLESS	2
9	VF14264	BOLT, M6X50, HEX STAINLESS	2
10	VF13614	WASHER, D6.3XD12.6X1.2, STAINLESS	12
11	VF89509	NUT, THUMB, M6	6
12	80398A	SCREW, M5X35	3
13	VA13482	WASHER, D5XD10X1.0, STAINLESS	6
14	VF14514	NUT, NYLON INSERT, M5	3
15	VF13491	PH SCREW, M4X12	2
16	VV13664	WASHER, D4XD12X1MM, STAINLESS	2
17	VF89508	BUSHING	3
18	VF89809	WHEEL, SQUEEGEE	3
19	VF85698	BOLT, M8X55	2
20	VF89510	THUNB BOLT	2

ELECTRICAL

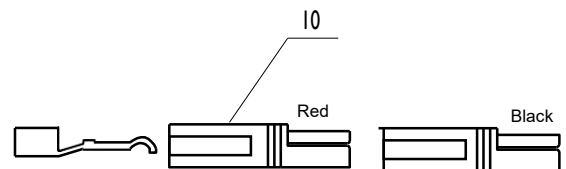
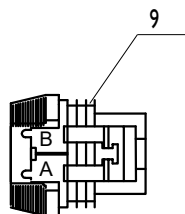
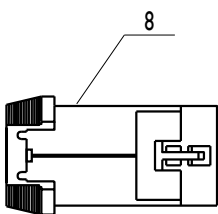
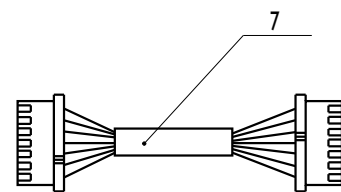
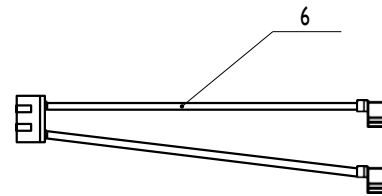
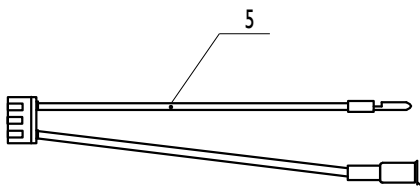
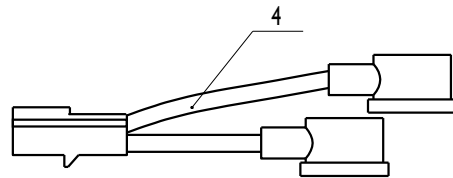
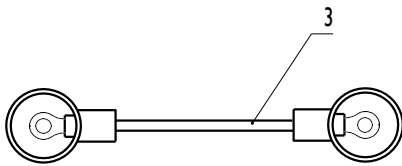
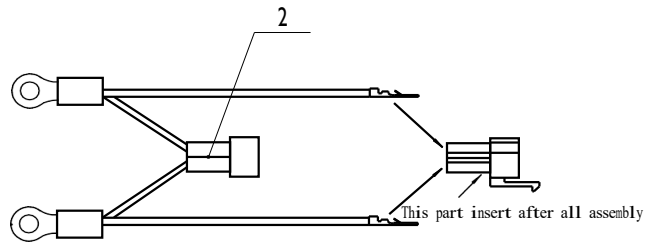
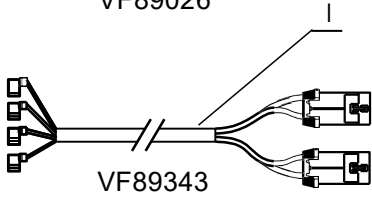
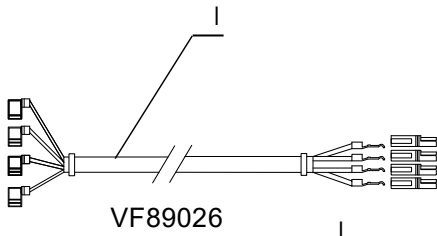

ELECTRICAL PARTS --- FANG 15B			
Item	Part No.	Description	Qty
1	VF89026	MOTOR WIRE (Up to serial number FANG15B 004160)	1
	VF89343	MOTOR WIRE (From serial number FANG15B 004161)	1
2	VF89022	MAIN POWER WIRE	1
3	VF89021	BATTERY CONNECT WIRE	1
4	VF89036	POWER WIRE	1
5	VF89024	CHARGER INPUT WIRE	1
6	VF89620	KIT, 4-LEG SWITCH	1
7	VF89025-3	COMMUNICATION WIRE	1
8	VF85450A	WATERPROOF CONNECTOR	1
9	VF85450C	WATERPROOF CONNECTOR	1
10	VF85727	CONNECTOR TERMINAL	1
	VF85723	RED CONNECTOR HOUSING	1
	VF85724	BLACK CONNECTOR HOUSING	1

**TROUBLESHOOTING**

Trouble	Possible Cause	Remedy
The machine does not work, indicator light (51) do not turns on	The battery connector is disconnected	Connect
	The batteries are completely discharged	Charge the batteries
	The power line disconnected from the power	Connect
The machine does not work, indicator light (51) display red	The batteries are discharged	Charge the batteries
Brush motor does not work, brush indicator light (52) does not turn on.	The PCB or key board is broken	Change the PCB or key board
Brush motor does not work, brush indicator light (52) flashes	The deck motor is overloaded	Use less aggressive brushes suitable for the floor to be cleaned
	Obstruction preventing the brush from rotating	Clean the brush hub
Vacuum system motor does not work, vacuum motor indicator light (53) does not turn on	The PCB or key board is broken	Change the PCB or key board
Vacuum system motor does not work, brush indicator lights (53) flash	The vacuum motor is overloaded	Check the vacuum motor
Insufficient vacuuming / water pickup	The recovery tank is full	Empty the recovery tank.
	The hose is disconnected from the squeegee	Re-connect
	Vacuum assembly is clogged	Clean or check
	The squeegee is dirty, or the squeegee blades are worn or damaged	Clean and check the squeegee
	The recovery tank do not latched closed	Lock the latch (17)
	The tank cover is not properly closed, or the gasket is damaged	Close the cover properly or replace the gasket
The solution flow is insufficient	The solution filter is dirty	Clean the filter
	The solution is empty	Refill solution tank
	Solution flow control valve (31) is clogged	Clean the valve
	The solution is dirty	Clean the solution
The squeegee leaves marks on the floo.	There is debris under the squeegee blades	Remove the debris
	The squeegee blades are worn, chipped or torn	Replace the blades

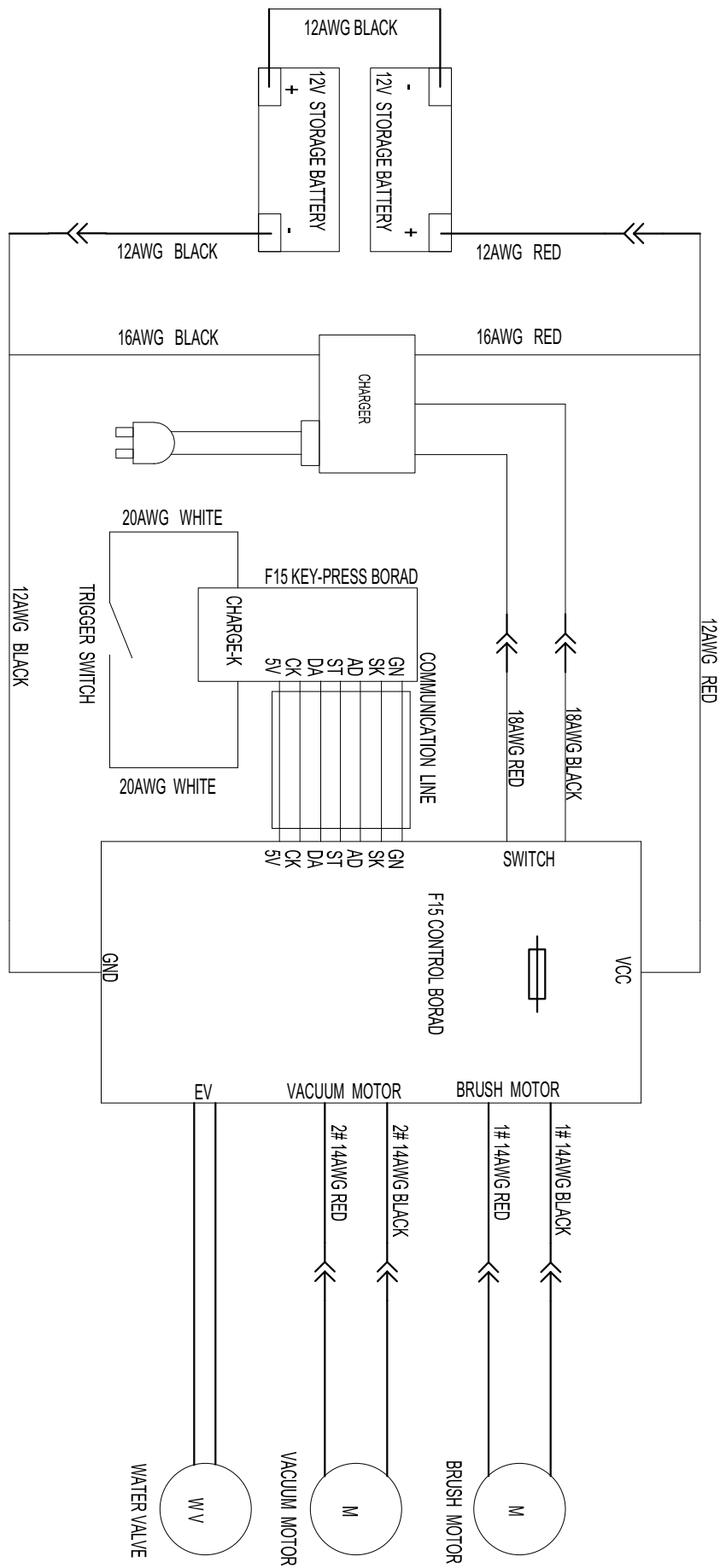

[www.usviper.com](http://www.usviper.com)

